

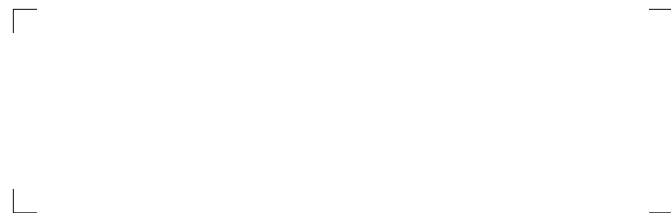

# **DOOR OPERATOR OWNERS MANUAL**



**This document contains important maintenance and safety information to be reviewed after Installing and Operating the door.**

**Retain this document for future reference**

# Table of Contents

---

TABLE OF CONTENTS	2
INTRODUCTION	3
GLOSSARY OF TERMS	4
DRIVE TYPES	5
OPERATING CONDITIONS	5
MAINTENANCE CHECKLIST	6
CLEANING THE DOOR	6
OVERALL DOOR INSPECTION	7
GEAR BOX(S)	7
DRIVE AND LIMIT CHAIN	8
LIFT CABLES	8
PHOTO EYES	8
MAIN ROLLER BEARINGS	9
DRIVE SHAFTS	9
ELECTRICAL	9
ELECTRIC BRAKE	
CENTER MOUNT (CM) DOOR	10
SIDEWINDER (SW) DOOR	11
WARNING AND SAFETY LABELS	12
ADJUSTING LIMITS	13
LOCKING SYSTEM	13
AUTOLOCK	14
HINGES	14
EXTERIOR CLADDING-OPTIONAL	14
WEATHER SEALS	15
COLUMN FOLLOWER-OPTIONAL	15
MANUAL OPERATION	16
WARRANTY	17

# Introduction

Congratulations on your purchase of a Diamond Door quality bi-fold door system. Following a few simple steps will help ensure you get years of trouble free operation.

## IMPORTANT INSTALLATION INSTRUCTIONS

### WARNING

#### To reduce the risk of SEVERE INJURY or DEATH:

1. READ AND FOLLOW ALL INSTALLATION WARNINGS AND INSTRUCTIONS.
2. Refer to the electrical installation manual for details on hooking up the door to line power.
3. NEVER let children play with or operate the door, keep remote controls (where applicable) out of the reach of children.
4. Keep people and equipment clear of a door that is in motion and keep the moving door in sight until it is completely closed or opened. NO ONE SHOULD CROSS THE PATH OF A MOVING DOOR.
5. Test and check the doors safety features once a month, adjust the upper and lower limits as needed. Failure to adjust the operator properly may cause severe injury or death.
5. Power connection to the door should be made by a qualified electrician after the door has been securely mounted onto the building.
6. Locate the up/down/stop wall station within sight of the door and at a minimum height of 5 feet to keep it out of the reach of children.
7. Ensure all guards are in place before operating door.
8. Ensure all warning labels are visible and intact prior to operating the door.
9. Follow the maintenance schedules outlined in this manual.
10. SAVE THIS INSTALLATION AND OWNERS MANUAL FOR FUTURE REFERENCE

## Door Wiring and Controller Hookup

**All Electrical connections and wiring should be performed only by qualified electricians, refer to the Electrical Installation Manual.**

# Glossary of Terms

---

**Brake Test** - a method of testing the safety system that prevents a bi-fold door from closing by gravity when the motor is not running.

**Door Operator** - overall opener system; motor, control box and lifting mechanism.

**Input Screw (ref. gear box)** - part of the gear box that attaches to the motor. The motor turns the input screw (shaft) of the gearbox. The input screw is threaded, and turns the gear within the gearbox.

**Limit Switch(es)** - generally refers to the limit switches found inside the black electrical box, which control the limits of how far the door is allowed to open and close.

**Overall Units** - entire door system.

**Photo Electric Sensors** - safety sensors (like photo eyes) which are intended to cut electrical power and stop the door if activated. Typically installed on either side of the door frame near the floor, to prevent the door from closing if an object or person is in the doorway.

**Pillow Block Bearings** - main drive shaft bearings, in a cast steel pillow block housing (end of main drive shaft) attached to door with 2 bolts.

**Sight Glass** - clear window on the gearbox, allowing you to see the oil level

**The Overload** - electrical circuit breaker, sometimes referred to as the overload switch. Usually found on the side of the black electrical box. Note: for 3 Phase doors, the overload is found on the inside of the box, with controls to adjust the amperage.

**Track Angles** - steel angle-iron tracks attached to building columns, on which the door travels up and down. (usually a 3x3 or 3/4 angle-iron)

**Column Follower** - hinged safety catches found on buildings that have I-beam building columns. Wind catches track along inside of building column to prevent the door from swinging outwards, away from building, in the event of operation in high winds.

# Drive Types

Your bi-fold door will have one of the following drive types:

1. Single motor mounted at one side of the door (Sidewinder), attached directly to the drive shaft.
2. Single motor center mounted with a chain reduction, coupled to the drive shaft.
3. Multiple motors with chain reduction, coupled to the drive shaft.

Please reference the following diagrams to determine your drive type.

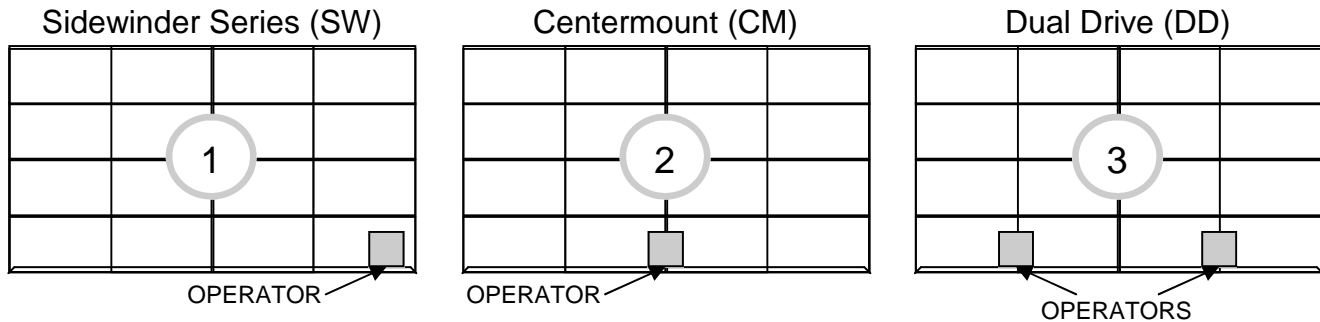

## Operating Conditions

### DO NOT OPERATE YOUR DOOR WHEN:

- a Proper maintenance has not been performed or door is clearly unsafe to operate.
- b Strong or excessive wind is blowing towards the door.  
In some cases, winds may blow in a direction and speed that may cause the door to lift away from the building. If this occurs:
  - Close all other doors and windows on the building (Keep other windows and doors closed while operating the Bi-Fold door.
  - Close Bi-Fold door immediately.
  - Check that the door rollers are resting next to the building before locking the door.
  - Make sure the locking fingers both catch the yellow latch brackets when locking.
  - Only open the door as much as is required to move equipment in or out and then close and lock the door.
- c The area around and under an open door is not clear.
- d Objects or people are in front of the door opening, obstructing door travel.
- e There is inadequate or improper electrical supply (Damage may occur).

### **IMPORTANT**

**Do not leave the door open when it is raining or snowing. Electrical components may be exposed to moisture and corrode or freeze causing the door to operate improperly or not at all.**

# Maintenance Checklist

	Check Every	3 Months	12 Months
Overall Door Inspection		X	
Gear Box(s)		X	
Drive and Limit Chain		X	
Lift Cables		X	
Photo Eyes		X	
Main Roller Bearings		X	
Drive Shaft			X
Electrical			X
Center Mount Electric Brake			X
Sidewinder Electric Brake			X
Warning and Safety Labels			X
Adjusting Limits			X
Locking System			X
Autolock			X
Hinges			X
Exterior Cladding-OPTIONAL			X
Weather Seals			X
Column Follower-OPTIONAL			X

## Cleaning the Door

Power to the door should be turned off before cleaning

Wash the exterior of your door with a garden hose and clear water.

**Be cautious when using high-pressure washing systems or chemicals for cleaning as they may cause damage to door components.**

Use care when cleaning the interior of the door. Avoid liquid contact with electrical components and moving parts.

An air hose and blower may be sufficient to remove dust build-up.

Hand-wash hard surfaces with a mild detergent to remove dirt and/or grease build-up.

### Door Wiring and Controller Hookup

**All Electrical connections, repairs, wiring, and maintenance should be performed only by qualified electricians, refer to the Electrical Installation Manual.**

### IMPORTANT

**Always disconnect the power to the door before performing any maintenance or cleaning**

# Overall Door Inspection

---

- 1 Visually inspect general door condition (walk-around).
- 2 Fully cycle of door from open to close.
  - a Listen for abnormal sounds.
  - b Check that the door stops at its upper and lower limits, if not, adjust the limits as needed as described on page 10.
  - c Examine the cable as they spool around the driveline, they should not overlap as the door raises up.
  - d Compare the rollers on both sides of the door. They should tracking evenly and be relatively centered on the track angles.
  - e Watch for any signs of binding or hooking as the door opens and closes.
- 3 Ensure the chain guard(s) and cable guards are in place and not damaged and that the electrical enclosure is closed and secured.
- 4 Check for and remove any debris on the door.

## Gear Box(s)

---

Unless there is evidence that oil has been leaking out, the oil in the gear box should be checked every 3 months. Look for visible residue, or a stain on the floor.

Normal break-in period for a gearbox would be 200-500 cycles.

To Check the Gear Box:

1. Disconnect electrical power to the door.
2. Remove safety shields on CM, and DD doors to uncover the sprockets and chains.
3. For gear boxes with a sight glass, check to see if oil level is adequate.
4. For gear boxes not equipped with a sight glass, remove vent plug and visually note oil level.
  - a. For SW doors, fill up to the plug opening.
  - b. For all other doors, fill the oil to a minimum of the center line of the output shaft with the door in the closed position.
5. Reinsert plugs, and attach all safety guards.
6. Turn on electrical power.

Low usage doors typically need the oil changed after several years. When changing the oil, be sure to use a good quality, Full Synthetic 75W90 Gear Oil.

Match up your gear box part number with the chart below to determine the amount of oil to put in.

Drive Type	Size	Volume
Auto-Lock Only	45 Series	100ml
Sidewinder	63 Series	300ml
Sidewinder	85 Series	750ml
Center Mount/Dual Drive	300 Series	2400ml
Center Mount/Dual Drive	325 Series	2400ml
Center Mount/Dual Drive	100 Series	2600ml
Center Mount/Dual Drive	120 Series	3000ml

### **IMPORTANT**

**Always disconnect the power to the door before performing any maintenance or cleaning**

# Drive and Limit Chain

---

Check:

1. For even tension.
2. For chain wear.
3. Chain alignment between upper and lower sprockets
4. Sprocket set screws are snug.
5. That all safety shields are in place.
6. Limit switches after any major drive chain adjustments (*see pg. 10*).
7. That the chain is properly lubricated with chain lube spray or lightweight motor oil.  
(*Never use grease or silicone spray*).

# Lift Cables

---

With the door in the closed and locked position, check that the lift cables are not under tension and that they are not so loose that they may fall away from the Y-Pushers.

Check for consistent cable tension:

Unlock and open the door  $\approx$ 2 feet.

Check each cable by hand for similar tension.

Close and lock the door.

Adjust cables as needed so they have similar tension.

Visually inspect the cables for any frays or kinks.

Damaged cables should be replaced.

Cable replacement:

Close and lock the door, then disconnect electrical power.

Remove damaged cable(s).

Replace with new cable(s).

Check for consistent tension between cables.

Verify all safety guards are in place.

Reconnect electrical power.

**USE ONLY A GENUINE  
DIAMOND DOORS  
REPLACEMENT CABLE**

Use of an Incorrect Cable Size  
or Type May Be Dangerous  
and may Result in Premature  
Component Failure.

*Contact Diamond Doors for pricing and  
availability of replacement cable(s).*

# Photo Eyes

---

For doors equipped with Photo Eyes, check that the close cycle stops when something obstructs the path between sensors. Pass a broom or shovel through the optical path, if the door does not stop have the system checked.  
DO NOT stand in the door way when the door is in operation.

**IMPORTANT**

**Always disconnect the power to  
the door before performing any  
maintenance or cleaning**



# Main Roller Bearings

---

To Visually Inspect:

1. Unlock and open the door ≈2 feet.
2. Check that the snap rings securing the inner bearing to the outer sleeve are in place.
3. The roller bearing should roll smooth and quiet.
4. Inspect the grease seals, they should not be leaking.
5. Verify the set screws holding the bearing on the shaft are snug. If the bearing has shifted, move the bearing so the outer face of the bearing aligns with the outer face of the drive shaft and tighten the set screws.
6. Close and lock the door.

## Drive Shafts

---

Visually Inspect:

1. Drive Line Bushings-Check for wear and grease if applicable with a full synthetic grease.
2. Pillow Block Bearings-Check for wear and damage, and that the set crews are secure.  
Do not grease sealed units.
3. Connection Bolts-Check that all bearing and bushing mounting

.....  
: If any bushings or bearings are tightened or replaced, check the :  
: chain alignment—the sprockets should be in line vertically. :  
.....

## Electrical

---

1. Disconnect electrical power to the door system.....
2. Inspect wiring, it should be...
  - Free of kinks, cracks, and breaks.
  - Free to bend and move at hinge locations.
  - Secure at all connection points.
3. Check wall station control.
  - Up / Down / Stop buttons should move freely and not stick.
  - It should be cleaned inside and out (carefully use compressed air).
4. Inspect the limit switch nuts located inside the electrical box.
  - Look for wear and make sure they are secure.
  - Threaded shaft should have a light amount of grease applied if the it is dry.
  - Adjust as needed (See Page 11 for instructions).
5. Check Safety Switch on manual locking doors (found in the handles cradle in the locked position).
  - The switch should have ≈1/4” of travel when depressed.
  - The handle should securely hold the switch in the depressed position.
6. Reconnect electrical power & perform voltage check (should +/- 3 volts of designed operators rating).

**IMPORTANT**  
**Always disconnect the power to the door before performing any maintenance or cleaning**

# Electric Brake

## The Electric Brake on top of each motor on Center Mount Doors (CM)

### —Electric Brake Test:

1. Connect and turn on electric power to test the brake.
2. Open the door about half way and begin closing the door, then press the stop button. The door should come to a stop almost immediately.
3. If the door free wheels more than a few inches, the brake may need to be serviced.



Fig 1

### —Brake Inspection:

1. Disconnect power to the door.
2. Remove the 3/8" hex nuts that hold the cover in place (see Fig 1).
3. Push plunger by hand, it should move easily and come back out on its own (see Fig 2). While depressed, the center shaft should rotate easily and when released, the shaft will not turn.
4. Connect power and cycle the door a few inches. Watch the operation of the plunger to verify that it travels fully into the brake coil (A second person may be required for this step).
5. Replace brake if it fails to cycle or move properly.

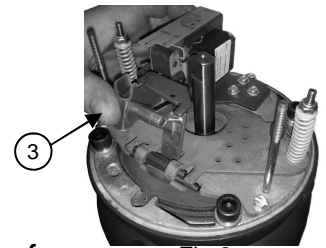

Fig 2

### —Adjusting Brake Tension:

1. Disconnect electrical power to the door.
2. Remove the 3/8" hex nuts that hold the cover in place (see Fig 1).
3. Tighten evenly both black socket-head cap screws with a 3/16" allen key 1/8 of a turn at a time.
4. Reconnect power to the door and perform Brake Inspection above, the brake should be completely disengaged during operation and may need to be adjusted.
5. Repeat steps 1 through 4 as needed.

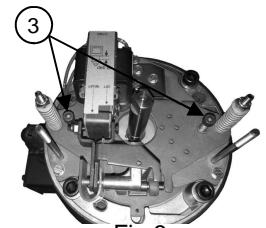

Fig 3

## **IMPORTANT**

**Always disconnect the power to the door before performing any maintenance or cleaning**

## The Electric Brake is between the motor and the gearbox on Sidwinder (SW) doors,

### —Electric Brake Test:

1. Connect and turn on electric power to test the brake.
2. Open the door about half way and begin closing the door, then press the stop button. The door should come to a stop almost immediately.
3. If the door free wheels more then a few inches, the brake may need to be serviced.

### —Brake Inspection:

1. Disconnect power to the door.
2. Remove the 4 nuts that hold the 3 components together and separate the housing and base of the brake assembly (see Fig 1).
3. Push plunger by hand, it should move easily and come back out on its own (see Fig 2). While depressed, the center shaft should rotate easily and when released, the shaft will not turn.
4. Replace brake if it fails to cycle or move properly.
5. Reassemble the drive assembly, connect power and perform a Brake Test.

### —Adjusting Brake Tension:

1. Disconnect electrical power to the door.
2. Remove the 4 nuts that hold the 3 components together and separate the housing and base of the brake assembly (see Fig 1).
3. Tighten evenly both black socket-head cap screws with a 3/16" allen key 1/8 of a turn at a time.
4. Reassemble the drive assembly, connect power and perform a Brake Test.
5. Repeat steps 1 through 4 as needed.

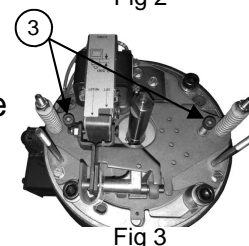
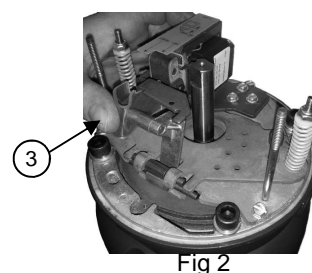

## **IMPORTANT**

**Always disconnect the power to the door before performing any maintenance or cleaning**

# Warning and Safety Labels

All Warning and Safety Labels should be in place. They should be periodically wiped with a damp cloth and kept visible at all times. Contact Diamond Doors for replacement labels.

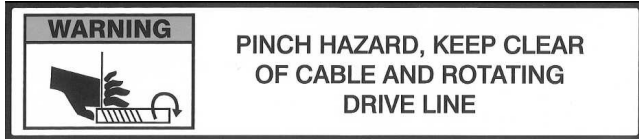

Affixed to the Bottom Truss  
(one by every cable location)

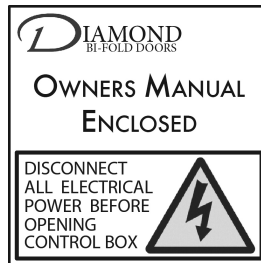

Affixed to Front Cover of Black Electrical Control Box



Affixed to the Safety Shield on the Operator



Affixed to Bottom Truss  
(centrally located near locking handle)



Affixed to Yellow Handle of Locking Mechanism  
(manual locking systems only)

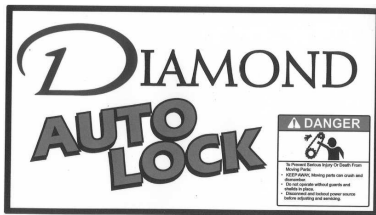

Affixed to Auto Lock Front Cover  
(Auto Lock System equipped doors only)

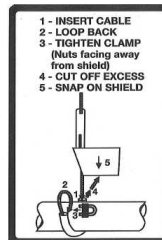

Affixed to Drive Line



Should be affixed near door controls  
(likely located on the building column)

# Adjusting Limits

- Limit switches in the control panel determine the limits of door travel.
- The lower limit or closed limit is set at the factory and will need little or no adjustment.
- The upper limit or open limit switch is set at only a few feet and will need to be set once the door is installed. Further slight adjustment may be required over the life of the door.
- Any adjustments should be made in small increments to prevent door sections contacting each other.

1 Press down on retaining plate tab.

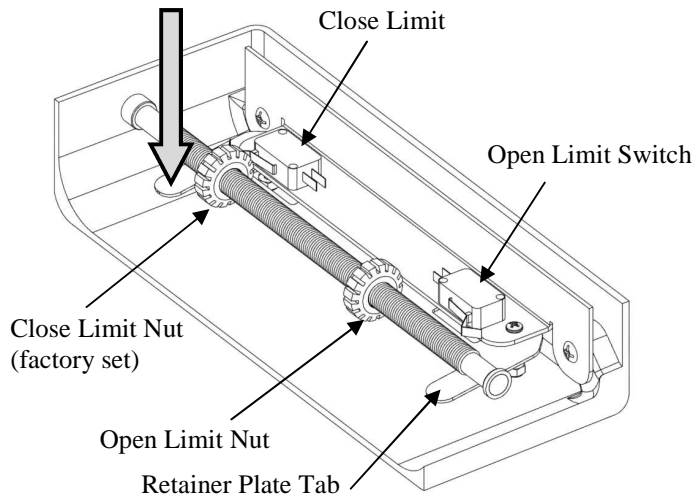

3 Release retaining plate and verify that it is fully seated into the notches of BOTH limit nuts. Watch movement of limit nuts during testing cycles to be sure everything is in place.

2 Adjust OPEN limit to set height. CLOSE limit is factory set and should need no adjustment.

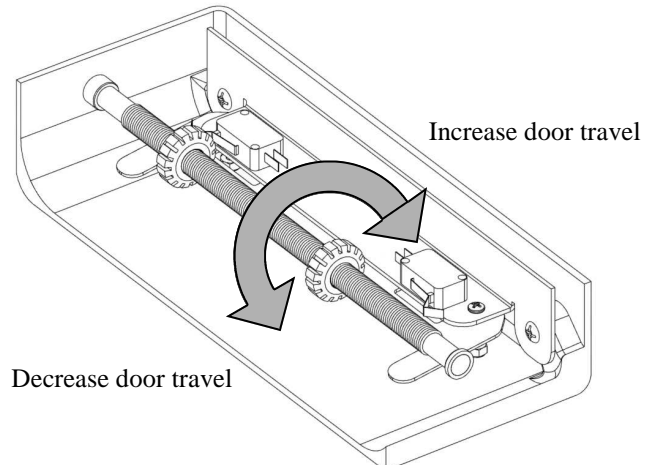

4 When door is fully closed, the cables should be slightly loose. The upper limit should be set so the door bridges DO NOT touch the frame. The door should stop at its MAXIMUM opening. Cycle several times to ensure limits are correctly set.

# Locking System

- 1 Inspect pillow block bearing seals and set screws.
- 2 Check that locking system secures the door to the building.
- 3 Adjust yellow latch bracket if the door does not close tight to the building (The galvanized lock pipes are factory set and should not require adjustment).
- 4 Check Safety Switch on manual locking doors (found in the handles cradle in the locked position).
  - a The switch should have  $\approx 1/4$ " of travel when depressed.
  - b The handle should securely hold the switch in the depressed position.

## IMPORTANT INSTRUCTIONS



## WARNING

**Do Not Allow the Door to Travel Beyond the Design Limits**

## IMPORTANT

**Always disconnect the power to the door before performing any maintenance or cleaning**

# Autolock

1. Open the door, stopping it approximately 6"-12" off the ground, allowing the AutoLock system to fully cycle to the unlocked position.
2. DISCONNECT THE POWER.
3. Check for any cracks in the gearbox housing.
4. Check for any loose hardware.
5. Check the wiring.
  - a. Tighten any loose wires, and connectors.
  - b. Zip-tie wires to keep them clear of moving parts.
6. Check horizontal locking rods.
  - a. Lubricate the sliding bolts with synthetic grease, and check for freedom of movement by forcing the locking finger into the locked position.
  - b. Check that the springs are intact and functioning by forcing the locking finger into the locked position. The spring should return the locking finger to the open position when released.
7. Lubricate cam & latch assemblies by removing the 3/8" bolts in the cam and latch assemblies. Use synthetic grease and then snugly reinstall hardware. Check the components for binding.
8. Reinstall Cover.
9. Reconnect the power.
10. Lower the door and visually observe the locking system as it cycles closed.

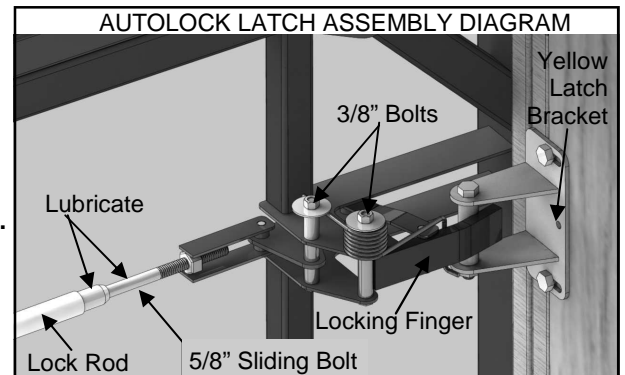

# Hinges

Inspect hinges for cracks, broken welds, and for overall condition, check that the pins are in place and secured with snap rings. Lubricate them if necessary.

# Exterior Cladding-OPTIONAL

1. Inspect overall condition of sheeting.
2. Tighten any fasteners that have come loose and replace any that are missing.

## IMPORTANT

**Always disconnect the power to the door before performing any maintenance or cleaning**

# Weather Seals

## 1. Check the Bottom Rubber Seal:

- a. For any damage.
- b. That it has not contracted and spans the clear opening width.

If gaps at the outer ends occur:

- i. Open the door a few feet.
- ii. Work the rubber to one side and pinch the rubber into the aluminum track at that end.
- iii. If it has contracted too much to pull the other side to the edge of the door, contact Diamond Doors for a short piece and insert it in to create a slip joint. Splice the small piece in by trimming 3" of the 'T' on the rubber seal that inserts into the aluminum extrusion. This will allow the end of the segment to slide into the existing seal.

## 2. Check the top White Canvas Weather Strip:

- a. For any damage or holes.
- b. That the silicone bead is present and intact along the outer edge by the top trim.

## 3. Check Foam Weather seals (Optional):

- a. The seals should not have any gaps.
- b. The seals should be firmly stuck to the door.

### IMPORTANT

**Repair damaged seals to prevent moisture related damage to the door and door components**

# Column Follower-OPTIONAL

1. Check if Column Follower moves freely on the pivot rod.
2. Confirm the cotter pins are intact.
3. Check for interference and freedom of travel as they travel up and down.
4. Make sure the retaining bolts are tight.
5. Verify that the deflector plate is secure at a position that deflects the column follower when the door closes.

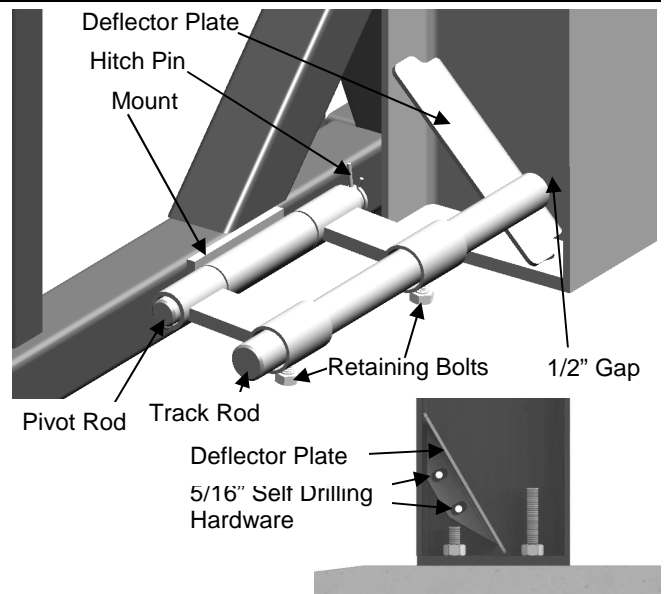

### IMPORTANT

**Always disconnect the power to the door before performing any maintenance or cleaning**

# Manual Operation

Open and close the door without power

If you experience a power outage to the door, electrical problems, or don't have electricity on-site, it is possible to operate the door manually. Follow these steps carefully to avoid potential injury.

1. TURN OFF MAIN POWER TO DOOR.
2. Unlock the door (if it is in the closed and locked position).
  - **Manual Lock** - rotate yellow locking handle 180° to unlock.
  - **Auto Lock** - Remove the dust cover on the end of the AutoLock motor to access the ½" Hex shaft.
3. Remove dust cover from top center of motor to access the ½" Hex shaft.
4. Use the ½" socket driver (supplied with door) and a drill or a ½" socket with a hand ratchet to cycle the autolock motor (if so equipped) to the unlocked or open position.
5. Manually release the brake on doors so equipped by clicking the dial into the released position.
6. Use the ½" socket driver (supplied with door) and a drill or a ½" socket with a hand ratchet to cycle the lift motor to open the door.
7. Re-engage the electric brake (if equipped) before removing the drill.
8. Replace all dust caps to their original position.

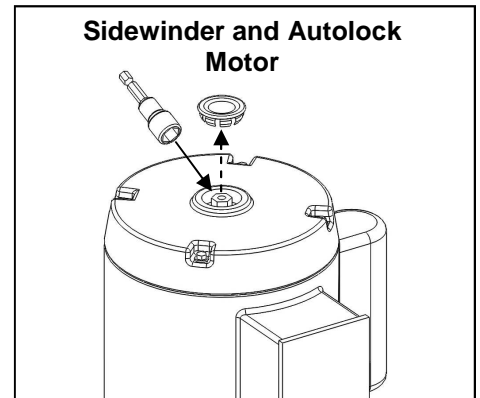
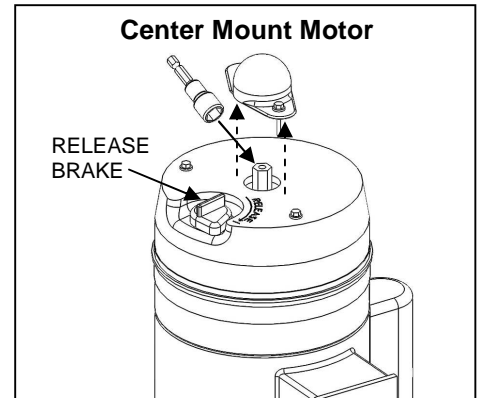

## IMPORTANT

**Never use an impact or hammer drill to cycle the door manually**

## IMPORTANT INSTRUCTIONS



## WARNING

- ◆ Use caution when releasing the brake, the door could start to freewheel down if the hex shaft is not held firmly. Reengage the brake to stop the door if needed.
- ◆ **NEVER** use an impact to open/close door.
- ◆ When manually operating the door, check that the open limit nut has **NOT** gone past the open limit switch.
- ◆ Never stand on a door when opening / closing it.

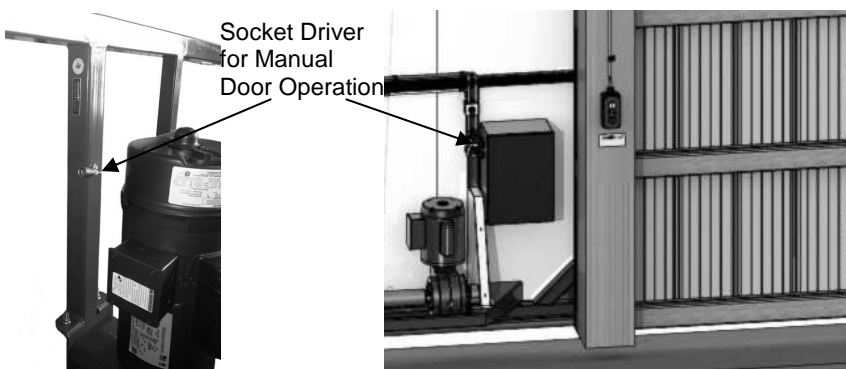

## IMPORTANT

**Always disconnect the power to the door before performing any maintenance or cleaning**





## Diamond Doors Inc. Limited Warranty

Subject to the limitations and conditions set forth below, Diamond Doors Inc. warrants from the date of original invoice, (a) the door system will be free of manufacturing defects in material and workmanship for a period of two (2) years in Canada, one (1) year in the United States of America; and (b) our doors will not warp, crack or buckle under normal intended use as a door, and for no other purposes, during the period of this limited warranty. Upon purchase of a Diamond Doors product, the buyer accepts this warranty and agrees it is the only official warranty, thereby excluding any other representation, warranty or condition, whether written or implied, except if stated in writing by an authorized Diamond Doors agent.

### ***These warranties are subject to the following restrictions:***

- Warranty is void if any modifications are made to the door system that change the weight and/or structural integrity of the door system, unless approved in writing by an authorized Diamond Doors agent. Examples may include any addition or removal from the door structure, adding windows/doors, using a heavier exterior sheeting/insulation, etc.
- Warranty is void if any modifications are made to the door system using after-market parts, unless approved in writing by an authorized Diamond Doors agent.
- Warranty is void if the door system is used for anything other than its intended use as a door, or other than normal/intended service conditions.
- Warranty applies only to doors that have been properly installed, and Diamond Doors reserves the right for itself or any authorized agent to inspect the door before approving a warranty claim.
- The buyer shall inspect material received from the Seller prior to installation so as to mitigate expenses involved in repairing, repainting, modifying or replacing product.
- **Any claim must be submitted in writing to the manufacturer within 30 days after discovery of the defect, describing the alleged defect, and must be received by Diamond Doors Inc. within the period of the warranty, otherwise the warranty shall be deemed null and void.**
- After receiving a written claim of alleged defect(s), Diamond Doors Inc. shall then have reasonable opportunity to inspect the product before any further action shall be taken.

### ***These warranties expressly exclude:***

- Defects or damage to the door or door components after delivery by Diamond Doors Inc., resulting from handling, shipping, transit, processing, improper storage or installation, or prolonged moisture contact or with corrosives and/or similar materials.
- Damage to the door resulting from any accident due to inadequate or defective building design, material or workmanship.
- Damage as a result of Acts of Nature (fire, flood, wind, earthquake, etc.), falling objects, external forces, explosions, or damage as a result of the actions of persons outside of Diamond Doors Inc. control.
- Problems due to misuse, abuse, or failure to follow care and maintenance instructions as found in the owners manual.
- Problems due to inadequate or incorrect power supply, including but not limited to; undersize electrical supply, undersize generator.
- Problems due to water and/or air infiltration due to improper or inadequate building construction/design, or improper installation of door system.
- Any costs related to the transportation of the replacement product.
- Any installation and labor charges related to the replacement product.
- Any non-factory customization or modifications made to the door by the buyer.
- Diamond Doors Inc. shall not be liable for any losses, damages or expenses whether direct, indirect, or consequential, caused by or resulting from the use of a defective or non-conforming door system, or for any other incidental or consequential damages. The total liability of Diamond Doors Inc. is expressly limited to the purchase price of the door system. Without limiting the generality of the foregoing, this warranty pertains to product only, and the seller shall not be liable for damages for or relating to labor or loss of use of structure or damage to contents of structure.

Diamond Doors Inc. reserves the right to provide products of similar quality and function, but of a different type or color in order to fulfill its obligations in the event it could not provide products of the original type/color, or if in its opinion, an alternate replacement could prevent the problem from reoccurring. Diamond Doors Inc. reserves the right to claim ownership of a replaced product, and may request that the replaced product be returned to the manufacturer at the buyers expense.

### **Maintenance to be done by the buyer**

The buyer commits to carry-out regular maintenance as recommended by Diamond Doors Inc. in the Owners Manual

### **DISCLAIMER**

EXCEPT FOR THE WARRANTY EXPRESSLY SET FORTH HEREIN, DIAMOND DOORS INC. HEREBY DISCLAIMS AND EXCLUDES ALL REPRESENTATIONS, WARRANTIES AND CONDITIONS, WHETHER WRITTEN OR ORAL, IMPLIED, STATUTORY OR OTHERWISE WITH RESPECT TO ITS PRODUCTS AND ALL COMPONENTS AND ELEMENTS THEREOF, INCLUDING, WITHOUT LIMITATION, IMPLIED WARRANTIES AND CONDITIONS OF MERCHANTABILITY AND FITNESS FOR PARTICULAR PURPOSE INCLUDING ANY AND ALL WARRANTIES AND CONDITIONS FOUND IN THE APPLICABLE SALE OF GOODS ACTS.

**This warranty policy is effective as of April 2011**



**DIAMOND  
DOORS**

**VERSION # 2.1.1**

**400 AIRPORT DRIVE  
WINKLER MB R6W 0J9 | CANADA  
PHONE 866.325.7600 | FAX 204.325.0908**