



30 MM POLYCARBONATE INSTALLATION MANUAL

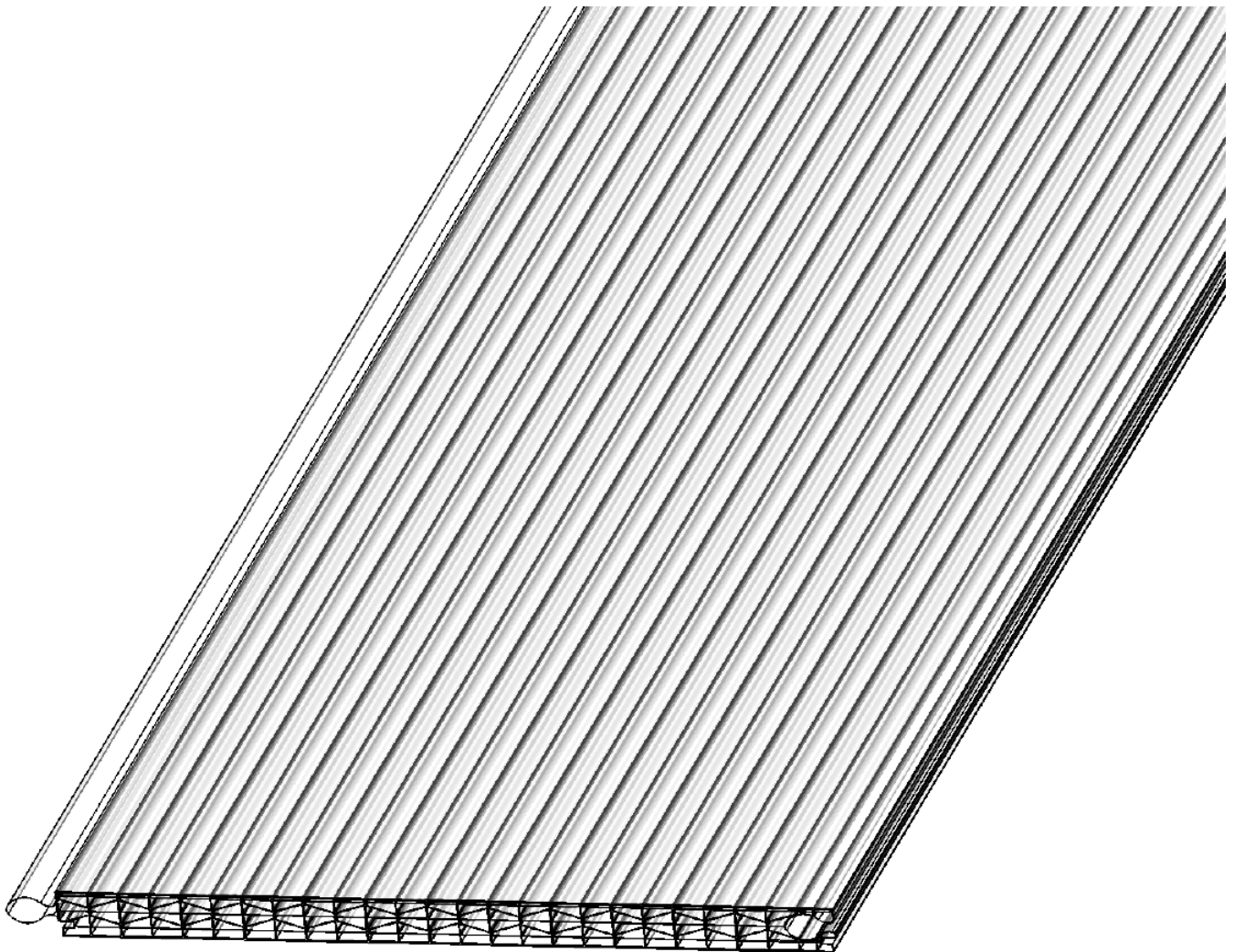

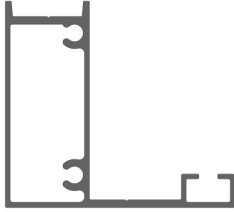

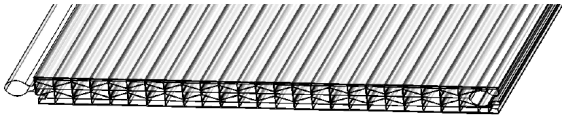



TABLE OF CONTENTS

Parts Glossary.....	1
Required Tools.....	1
Base Retainer.....	2
First Polycarbonate Panel.....	3
Remaining Polycarbonate Panels.....	4
Upper Retainers.....	4
Retainer Cap.....	4

Parts Glossary

Retainer Cap	
Upper Retainer	
Base Retainer	
Support Clip	
Stainless Steel End Cap	
Polycarbonate Panel	
#10-24 x 3/4" HWH TEK Screw	
#8-15 x 1/2" Pan Head Screw	

Required Tools

- Impact driver or drill driver
- 1/4" nut driver
- #2 Robertson head bit
- Measuring tape
- Utility knife
- Circular saw/ aluminum cutting blade
- General purpose lubricant

Install Base Retainer

1. Install horizontal base retainer sections

- Starting from one end, place 12' base retainers along horizontal member of door, securing with #10 - 3/4" TEK screws every 12".
- Trim the last base retainer as required.

Important: Install top canvas seal beneath base retainer along top of door.

Note: Cut base retainer, upper retainer and upper cap in sets.

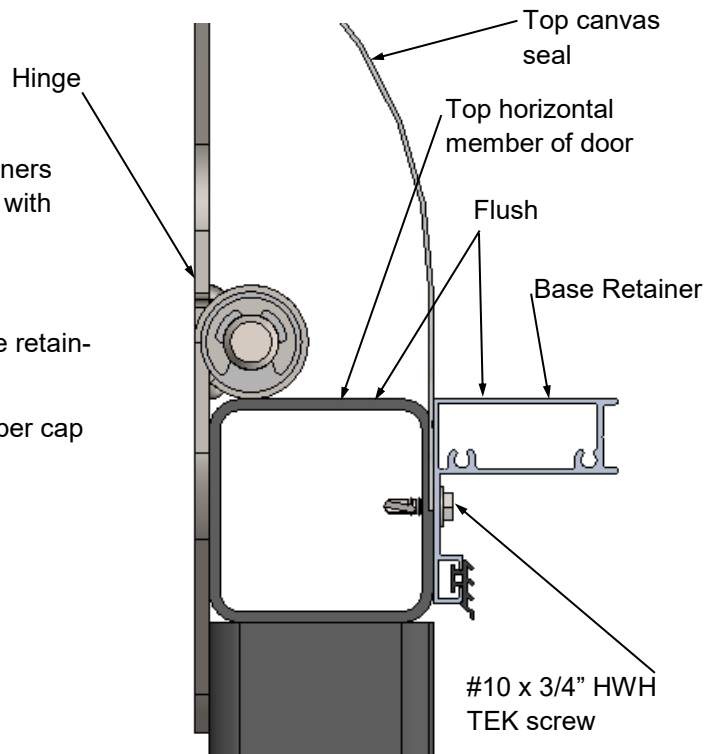
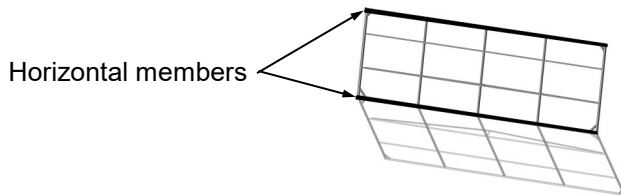

2. Install vertical base retainer sections

- Measure inside distance between installed retainers
- Cut retainer to fit measured length and install to door frame

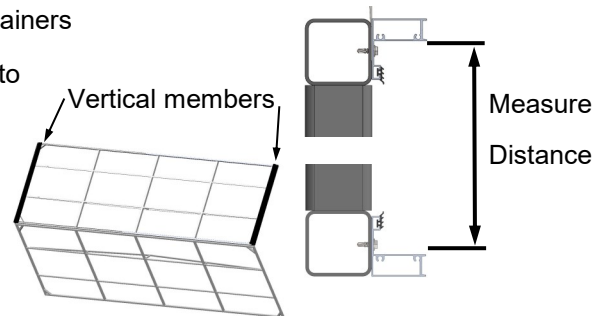

3. Install stainless steel end caps

#8-15 x 1/2" Pan head screw

Stainless steel end cap

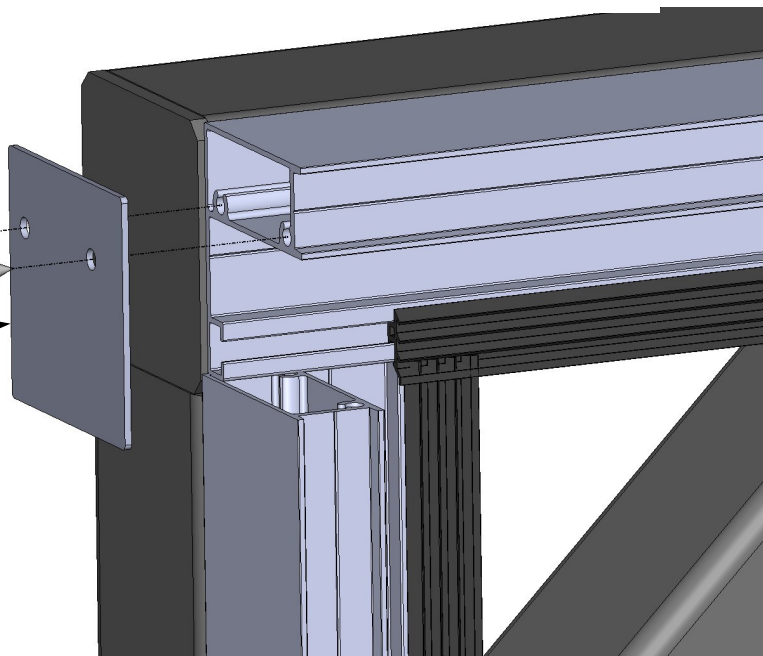

Install First Polycarbonate Panel

1. Cut lobe off first polycarbonate panel using a utility knife.

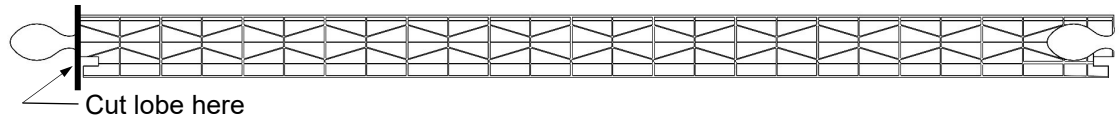

2. Place polycarbonate panel on base retainers starting at the left side of the door.

- Maintain approximately a 1/4" gap between the panel and both the horizontal and vertical retainers.

Important: Each panel has a sealant tape on the top and bottom. Ensure that the clear tape faces to the top and the silver breathable tape faces to the bottom.

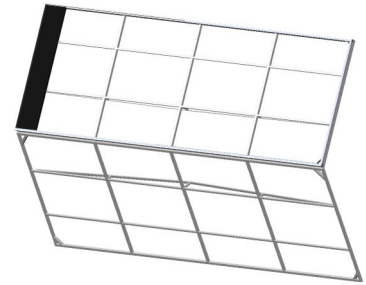

3. Attach the upper retainer to the base retainer along the left side of the door with #10 - 3/4" HWH TEK screws every 12 inches.

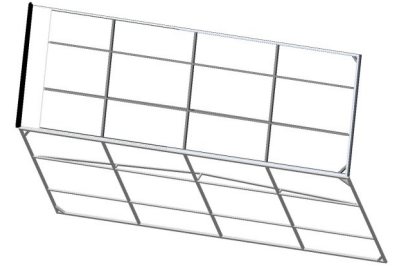

4. Install support clips on each horizontal member, inserting the support clip into the polycarbonate panel.

Note: If door is equipped with external horizontal foam seal (near the top of door), cut out sections beneath the support clips. Clips should be installed directly to door frame.

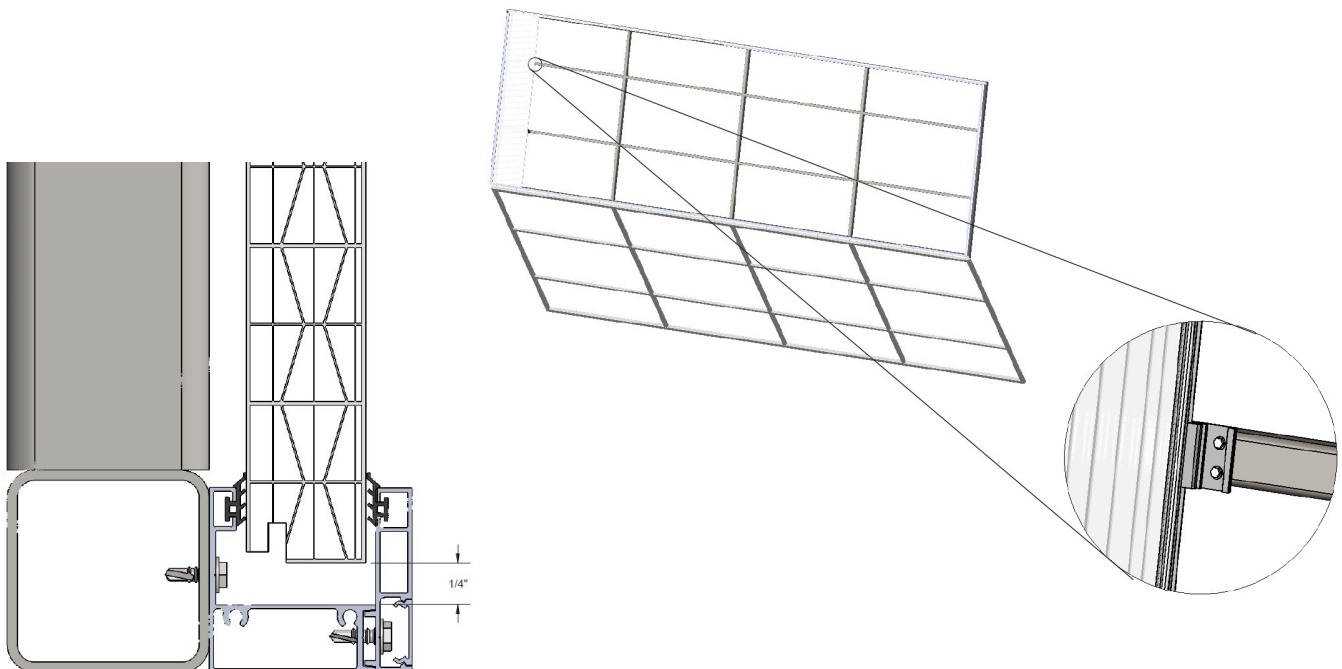

Install Remaining Polycarbonate Panels

- Apply lubricant to lobe of polycarbonate panel.

Note: Soap water, or a non-corrosive, no-residue lubricant recommended

- With the panel at an angle, insert the lobe, gradually snapping the full lobe into the groove of the first panel.
- Install additional support clip(s).
- Repeat the above steps, ensuring that all panels remain level with door frame.
- Cut the last polycarbonate panel to the appropriate width, leaving a 1/4" gap to the base retainer.

Install Upper Retainers

Install upper retainer to base retainer with a #10 - 1/2" TEK screws every 12".

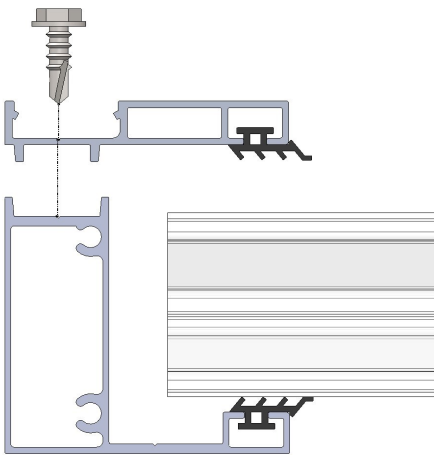

Install Retainer Cap

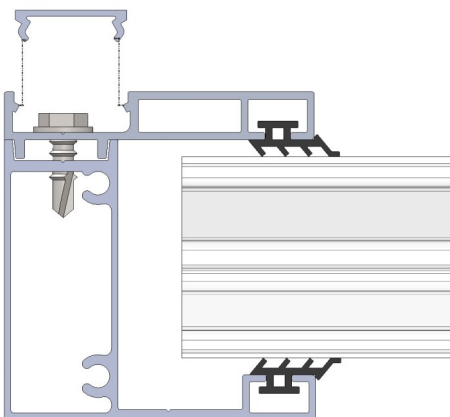



VERSION # 1.0.0

**400 AIRPORT DRIVE
WINKLER MB R6W 0J9 | CANADA
PHONE 866.325.7600 | FAX 204.325.0908
www.DiamondDoors.com**